

SPECIFICATIONS

OS REQUIREMENTS	Mac OS X 10.6/10.7/10.8 Windows XP/Vista/7/8 32/64 bit USB 2.0
SOFTWARE	Easy Stand Alone, ESA2 (PC & Mac)
OUTPUT PROTOCOL	DMX-512
CHANNELS	128
APPEARANCE	Black Glass
CONNECTIONS	Power (2 pins) DMX, (3 pins) Port (2 pins) Micro USB
INPUT POWER	120V input power to AC adapter. The controller comes standard with output voltage of 5.5V to 12VDC (AC/DC adapter) - 5.5V maximum with USB
CERTIFICATIONS	EC, EMC, ROHS, ETL, UL
CASE DIMENSIONS	3.38" x 3.38" x 0.39"
WEIGHT	0.24 lbs (110g)
TEMPERATURE RATING	0°C to 50°C
LISTING	Dry (IP20) Location
AVAILABLE MEMORY	
CHANNELS	STEPS
8	1691
16	1011
32	557
48	383
64	291
80	233
96	195
112	166
128	145
CONTENTS OF THIS DOCUMENT	
CT LIGHTSTRIP: LLED8300 or LLED8350	Page 2: Setup & Operation Page 3: Wiring Diagrams
CT WALL WASHER: ALS450T-CT	Page 4: Setup & Operation Page 5: Wiring Diagram
ESA SOFTWARE GUIDE	Page 6 - 7: LLED8300 & LLED8350 Page 8 - 9: ALS450T-CT

PRODUCT INFORMATION

- DMX standalone controller with glass face (128 channels)
- Package includes controller, USB cable, and connector block
- 3 touch-sensitive buttons (on/off/mode, previous, next)
- Up to 24 dynamic or static scenes (8 first visualized by an LED)
- Live intensity and color settings
- Programmable through included USB cable and control software
- Compatible with any DMX fixture or DMX LED decoder
- Ready to use (pre-loaded with 8 scenes)
- Latest ARM CPU technology
- One dry contact trigger port on PCB

ELECTRICAL

- Can be mounted on a standard electrical box with use of an EU to US adapter

INSTALLATION RECOMMENDATIONS

- Do not connect to more than 32 devices to a single controller
- Do not install in locations without proper ventilation
- Do not mount device on wood or plastic
- Do not install in wet or damp locations

INSTALLATION TOOLS REQUIRED

- Electric Hammer Drill
- 14.4 to 28 Volt Cordless Drill
- Phillips Bits
- Utility Knife
- Electrical Cord
- Marker
- Wire Stripper
- Long Nose Pliers
- Drill Bits - Concrete or Wood
- Electrical Three Ways
- Safety Glasses
- Measuring Tape
- Chalk Line



CALIFORNIA
ACCENT
LIGHTING
INC

DMX-CT-128C | INSTALLATION

Setup of DMX Controller (LLED8300 & LLED8350)

1. Unbox DMX Controller components. You will need the DMX Controller, power connector, USB cable, and RJ45 ethernet cable.

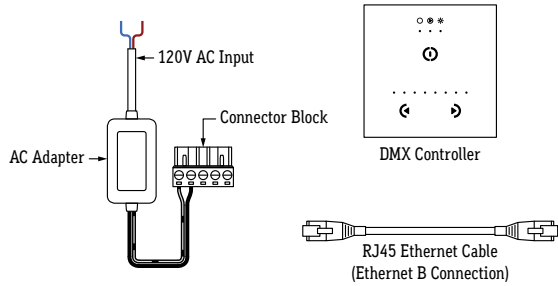

2. Cut one end of RJ45 cable near the connector and strip blue jacket, exposing about 1" of internal wiring.

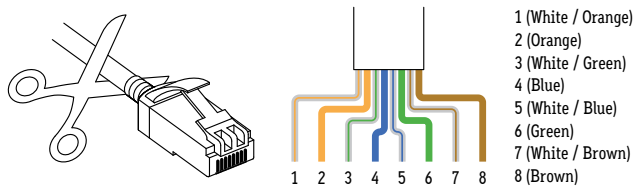

3. If applicable, connect 12VDC output wires from AC adapter to connector block. Connect the black / white wire to Power DC+ and the black wire to Power / Ground. Connect the brown / white wire to DMX Ground, the orange wire to DMX-, and the orange / white wire to DMX+ in the connector block. Cap off the five remaining wires.

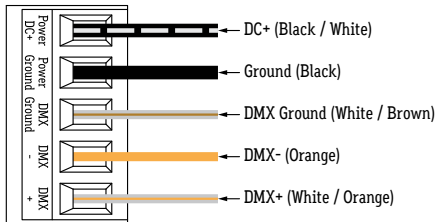

4. Connect AC adapter lead wires to 120V power supply (not included). The dark red wire is positive and the blue wire is neutral. Do not invert wires as it may damage the controller.

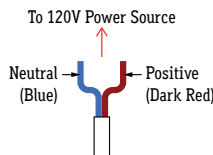

5. Install Nicolaudie Easy Stand Alone software to your device.
Link: <https://www.nicolaudie.com/en/esa.htm>
6. Connect controller via USB cable to a computer with Nicolaudie software installed, then program scenes into controller as desired. Remove USB cable after programming is complete.
Note: Refer to Operating ESA Software for a guide on creating and saving scenes.
7. Mount an electrical box (not included) to the wall where controller will be mounted. The controller fits on a standard 60mm electrical box with an EU to US adapter (by others).

8. Remove back plate from front panel. Insert a small flathead screwdriver underneath center tab and gently pry until back plate pops up.

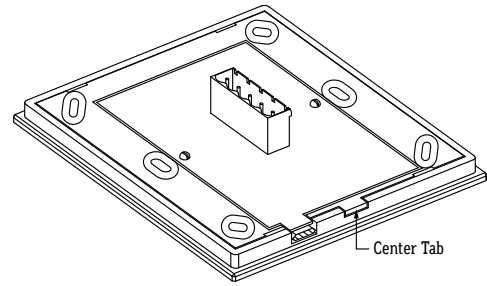

9. Insert assembled connector block into the receiving port on the back plate of controller.

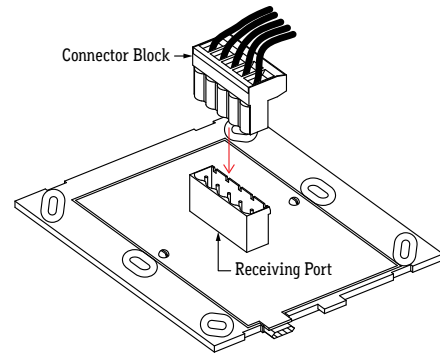

10. Mount controller interface onto the electrical box. If applicable, mount EU to US adapter (by others) to J-Box, then mount back plate to adapter. Secure with at least two screws, then snap the front panel onto the back plate. Wait at least 30 seconds for the touch sensitivity to adjust.

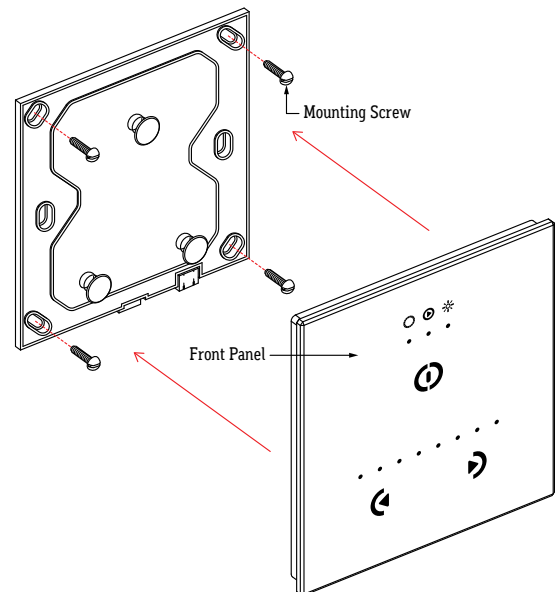

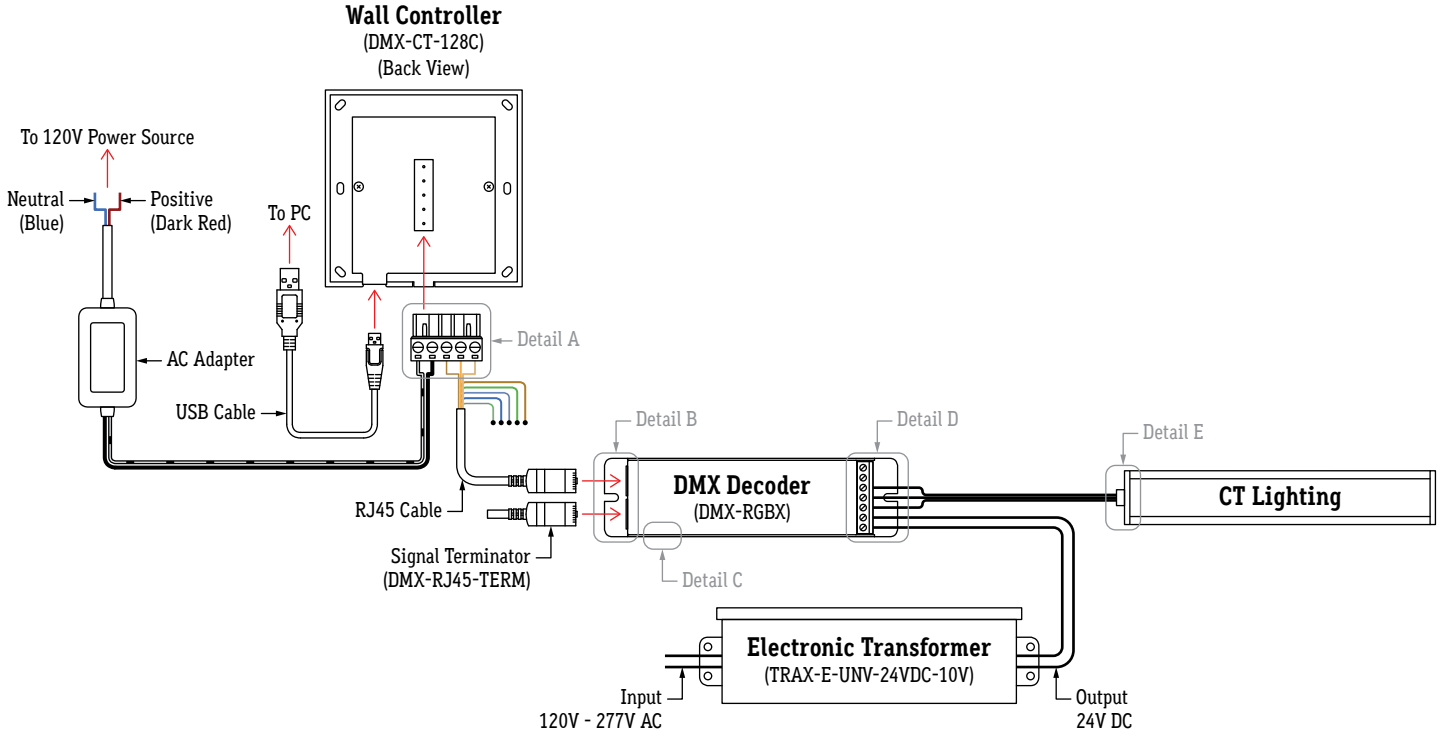

Detail A: Ethernet Connection to Connector Block

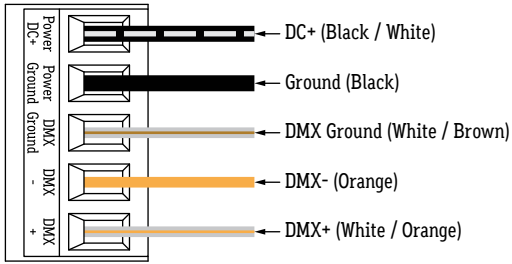

Detail B: Ethernet Ports

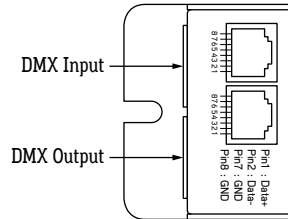

Detail C: DIP Switches

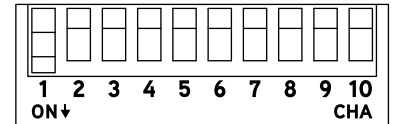

Set DMX address using DIP switches. Refer to DMX-RGBX (DMX-CT-5A) for more information on DMX addressing.

Detail D: Wiring to Decoder

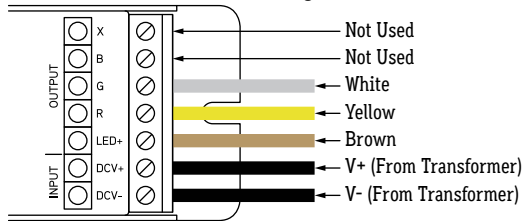

LLED8300

Detail E: Solder Connection

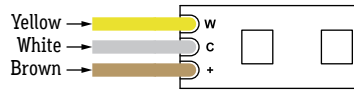

LLED8350

Detail E: Solder Connection

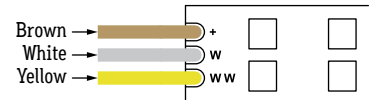



CALIFORNIA
ACCENT
LIGHTING
INC

DMX-CT-128C | INSTALLATION

Setup of DMX Controller (ALS450T-CT)

1. Unbox DMX Controller components. You will need the DMX Controller, power connector, and USB cable.

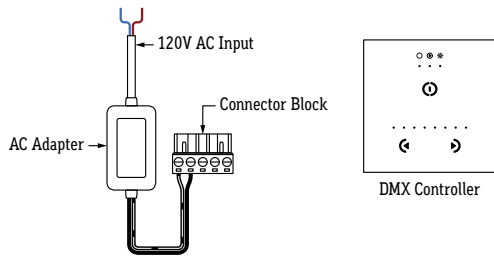

2. Cut the first female data cable near the connector and strip black jacket, exposing about 1" of internal wiring. The first data cable is located underneath the end of fixture with a digital interface on the end cap.

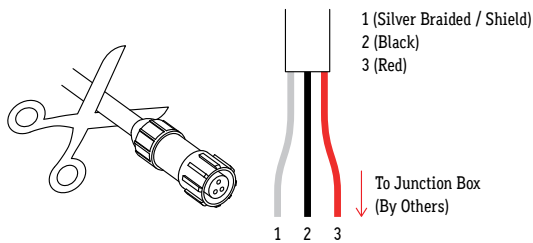

3. If applicable, connect 12VDC output wires from AC adapter to connector block. Connect the black / white wire to Power DC+ and the black wire to Power / Ground. Connect the brown /white wire to DMX Ground, the orange wire to DMX-, and the orange / white wire to DMX+ in the connector block. Cap off the five remaining wires.

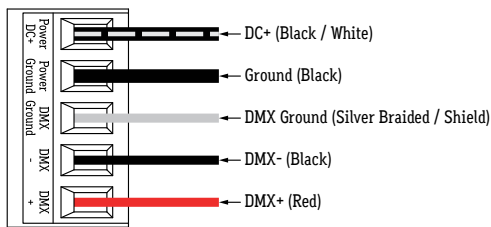

4. Connect AC adapter lead wires to 120V power supply (not included). The dark red wire is positive and the blue wire is neutral. Do not invert wires as it may damage the controller.

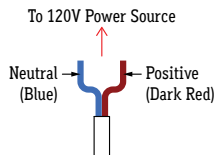

5. Install Nicolaudie Easy Stand Alone software to your device.
Link: <https://www.nicolaudie.com/en/esa.htm>

6. Connect controller via USB cable to a computer with Nicolaudie software installed, then program scenes into controller as desired. Remove USB cable after programming is complete.
Note: Refer to Operating ESA Software for a guide on creating and saving scenes.

7. Mount an electrical box (not included) to the wall where controller will be mounted. The controller fits on a standard 60mm electrical box with an EU to US adapter (by others).

8. Remove back plate from front panel. Insert a small flathead screwdriver underneath center tab and gently pry until back plate pops up.

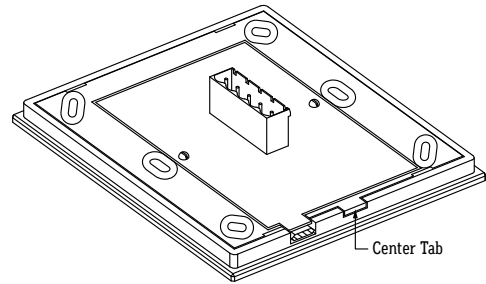

9. Insert assembled connector block into the receiving port on the back plate of controller.

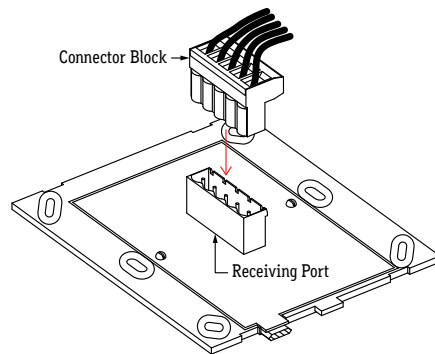

10. Mount controller interface onto the electrical box. If applicable, mount EU to US adapter (by others) to J-Box, then mount back plate to adapter. Secure with at least two screws, then snap the front panel onto the back plate. Wait at least 30 seconds for the touch sensitivity to adjust.

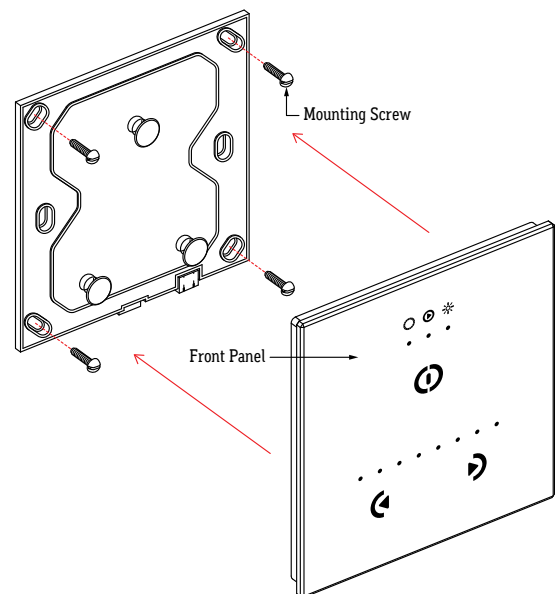

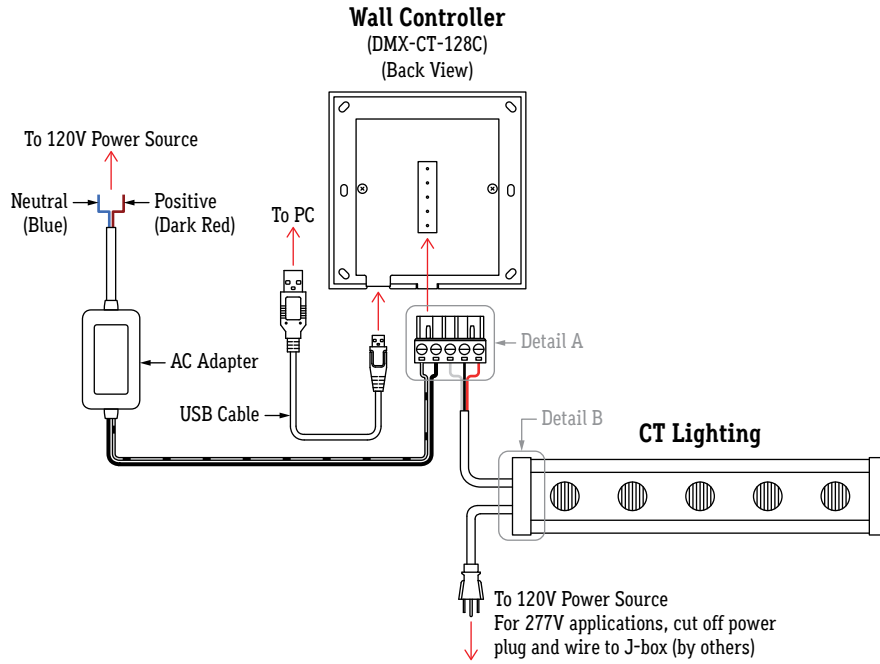

Detail A: Ethernet Connection to Connector Block

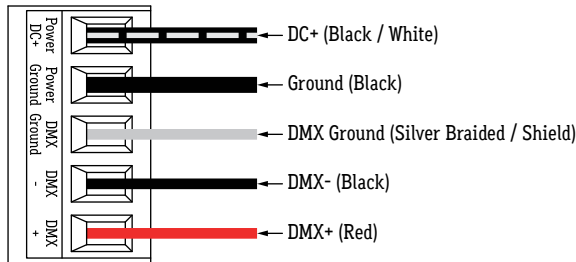

Detail B: Digital Interface

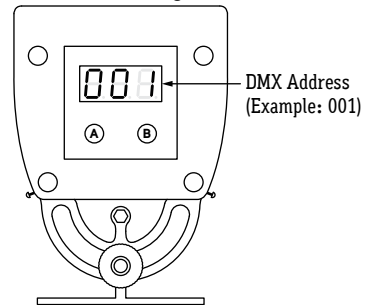



CALIFORNIA ACCENT LIGHTING INC

DMX-CT-128C | INSTALLATION

Operating ESA Software (LLED8300 & LLED8350) 1 of 2

1. Install Nicolaudie Easy Stand Alone software to your device.

Link: <https://www.nicolaudie.com/en/esa.htm>

2. Connect controller via USB cable to a computer with Nicolaudie software installed, then open software. It is recommended to create scenes while controller and lighting are connected to a computer. This provides instantaneous feedback while creating scenes.

3. The program will display a prompt to select your favorite operating mode. Select the STICK2 or STICK3A option and click OK.

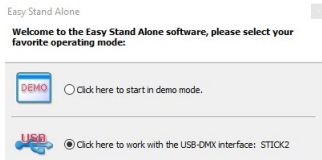

4. Set DMX address for each fixture connected to the controller. Set DMX address using DIP switches on the side of decoder. The sum of the value of each engaged DIP switch creates the DMX address.

Example: 1 + 4 + 32 = 37. DMX start address for this decoder is 37.

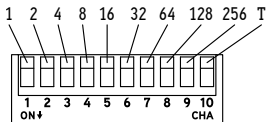

DIP switch value for each switch. Switch 10 is used for termination. Engage Switch 10 on the last decoder of a sequence to terminate signal.

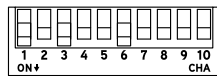

DMX address set to 37. Switches 1, 3, and 6 are engaged (on).

5. If all fixtures will be controlled together, continue to step 6a. If each fixture will be controlled independently, continue to step 6b.

6a. If all fixtures will be controlled together, set the DMX start address of each fixture to 1.

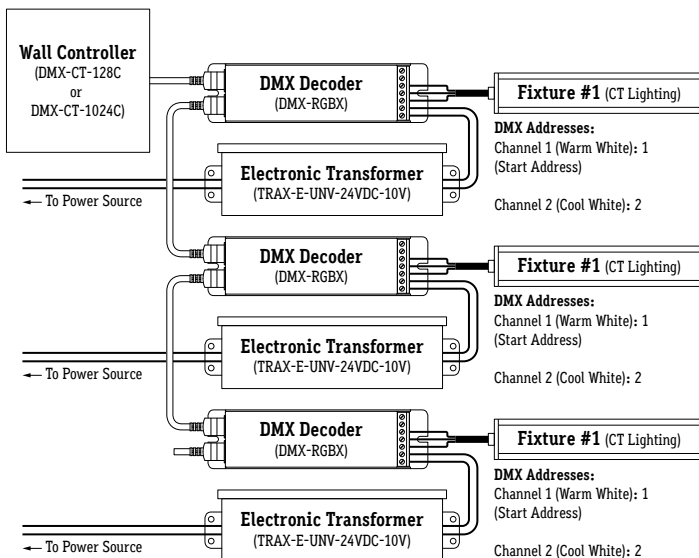

6b. If each fixture will be controlled independently, set the DMX start addresses in sequence. The start address controls the first channel (Warm White) of the CT fixture. The second channel (Cool White) will automatically be detected by the software and assigned DMX addresses within the DMX universe, which will be detailed later.

Example: Three fixtures with one decoder each. Set the DMX start address of the first fixture to 1. Set the DMX start address of the second fixture to 3. Set the DMX start address of the third fixture to 5, and so on. Refer to the below diagram.

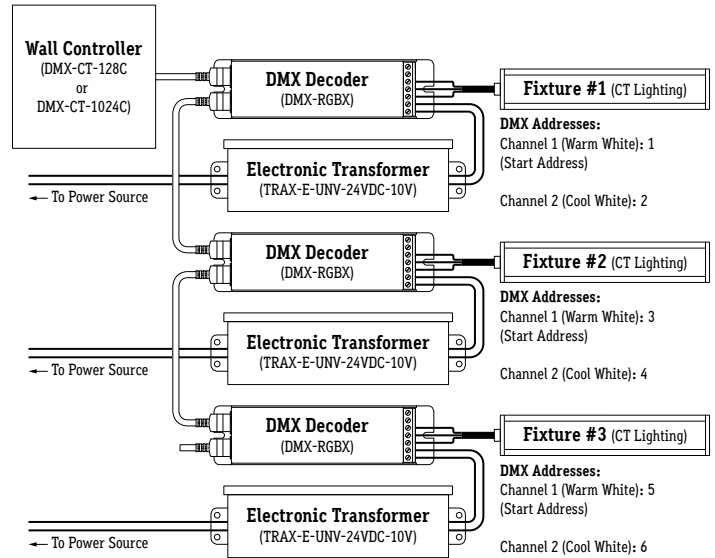

7a. The program will open to a blank show file by default. Patch each fixture to the DMX universe using the previously set DMX addresses. Under the Scan Library menu, in the generic folder, select "wccw". This tells the software that a 2 channel CT fixture is connected to the controller. The below diagram illustrates how to patch fixture #1. If all fixtures will be controlled together, skip step 7b.

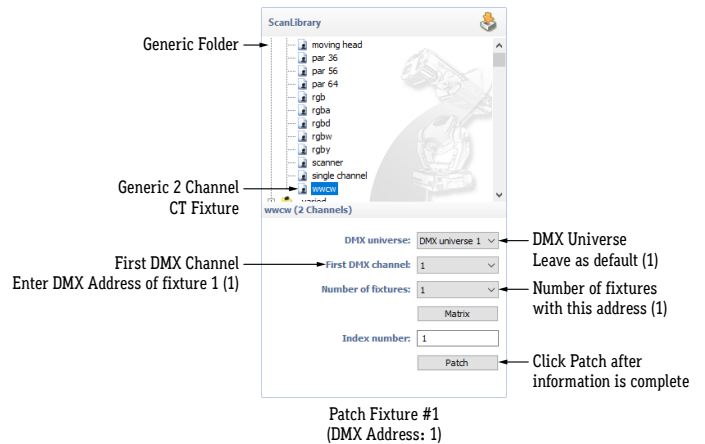



CALIFORNIA
ACCENT
LIGHTING
INC

DMX-CT-128C | INSTALLATION

Operating ESA Software (LLED8300 & LLED8350) 2 of 2

7b. Patch fixture #2 and fixture #3.

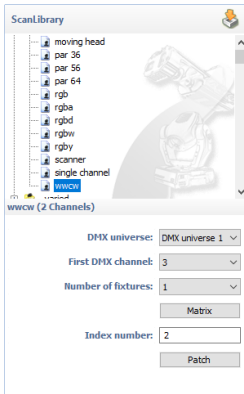

Patch Fixture #2
(DMX Address: 3)

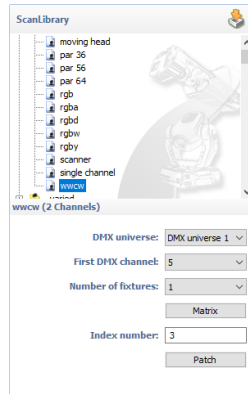

Patch Fixture #3
(DMX Address: 5)

8. To create a custom scene, click on the Editor tab at the top left of the interface. A new, blank scene named New Scene will appear by default.

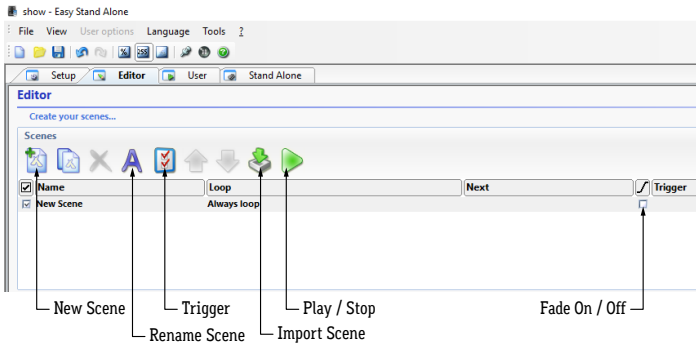

9. Each scene is made up of a series of steps. Create steps using the Steps menu on the upper right of the interface.

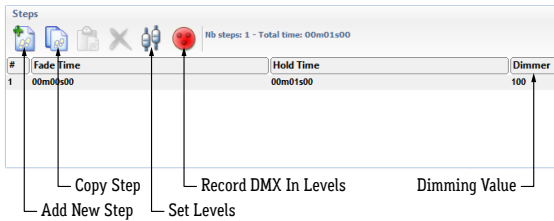

10. Set the color value of each channel for each step. Under the DMX Universe 1 tab, channel 1 - 2 controls the CT value of fixture #1. Channel 3 - 4 controls the CT value of fixture #2. Channel 5 - 6 controls the CT value of fixture #3. Use the slider to set each light level or enter light level in the light level display. Use the arrows at the top and bottom of slider track to fine tune the value.

Example: Channel 1 controls fixture #1 Warm White value (65).
Channel 4 controls fixture #2 Cool White value (65).

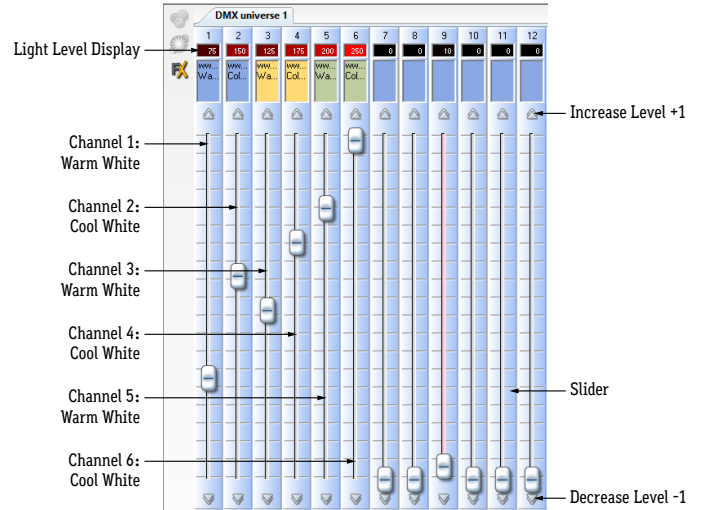

11. After setting CT values, set fade time and hold time in the Steps menu in the upper right of the interface. Double click 00m00s00 under Fade Time, then use the arrow keys to set desired time in minutes and seconds. Double click 00m00s00 under Hold Time, then use the arrow keys to set desired time. Double click Dimmer to set brightness value.

Example: Fade Time: 00m02s00 (2 seconds). Hold Time: 00m04s00 (4 seconds).
Dimmer: 100 (100% brightness).



12. Create additional steps as needed by repeating steps 9 - 11. Play your scene and make adjustments to the parameters as desired. When a scene is complete, save as a Show File (.dlm) as a backup on your computer. Create up to 24 scenes using the Editor tab.

13. Save scenes to the DMX Controller by using the Stand Alone tab in the upper left of the interface. Click the write memory button, then click OK. The program will write the scenes into the controller to be used independently from the computer.

Note: Writing the memory will erase all factory-programmed scenes from the controller.

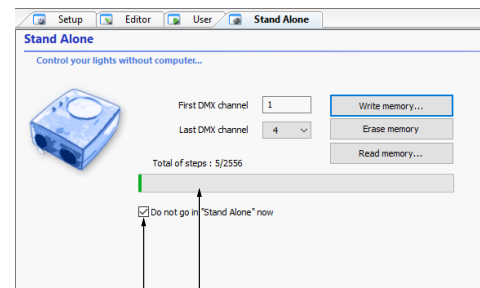

Uncheck if controller will be used exclusively while connected to a PC
Total memory usage. Create up to 2556 steps across 24 scenes.



1. Install Nicolaudie Easy Stand Alone software to your device.
Link: <https://www.nicolaudie.com/en/esa.htm>
2. Connect controller via USB cable to a computer with Nicolaudie software installed, then open software. The controller does not need to be powered to be programmed; however it is recommended to create scenes while controller and lighting are connected to a computer. This provides instantaneous feedback while creating scenes.
3. The program will display a prompt to select your favorite operating mode. Select the STICK2 or STICK3A option and click OK.
4. Set DMX address for each fixture connected to the controller. Set DMX address using digital interface on end cap of fixture.
Example: PXY value is 001. DMX address is 1.

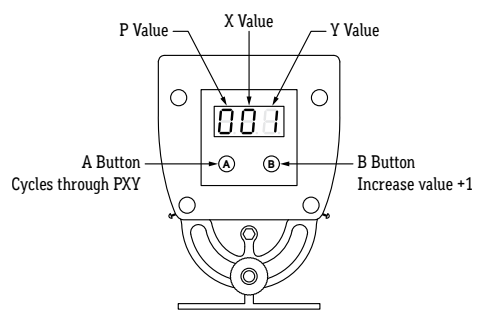

5. If all fixtures will be controlled together, continue to step 6a. If each fixture will be controlled independently, continue to step 6b.
- 6a. If all fixtures will be controlled together, set the DMX start address of each fixture to 001.

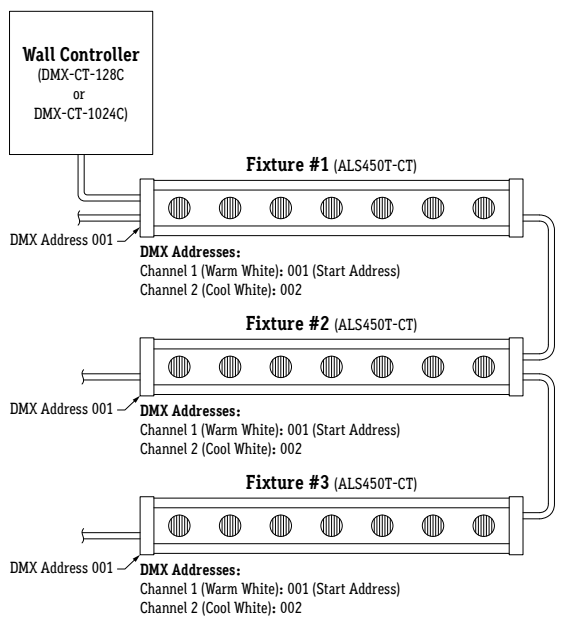

- 6b. If each fixture will be controlled independently, set the DMX start addresses in sequence. The start address controls the first channel (Warm White) of the CT fixture. The second channel (Cool White) will automatically be detected by the software and assigned DMX addresses within the DMX universe, which will be detailed later.
Example: Three ALS450T-CT fixtures. Set the DMX start address of the first fixture to 001. Set the DMX start address of the second fixture to 003. Set the DMX start address of the third fixture to 005, and so on. Refer to the below diagram.

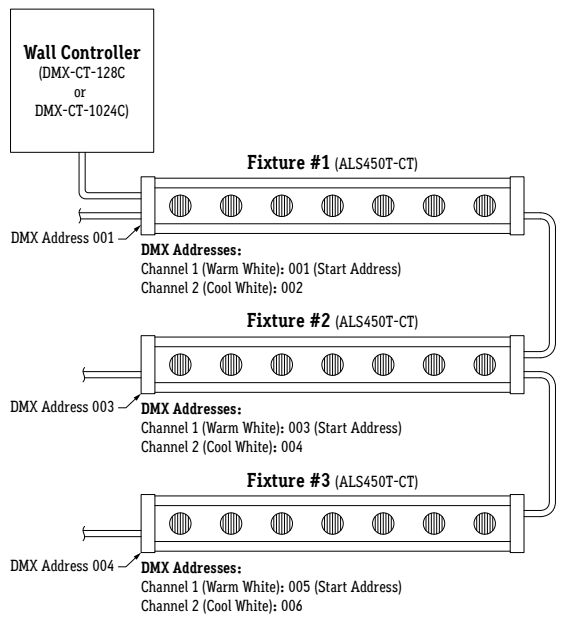

- 7a. The program will open to a blank show file by default. Patch each fixture to the DMX universe using the previously set DMX addresses. Under the Scan Library menu, in the generic folder, select "wvcw". This tells the software that a 2 channel CT fixture is connected to the controller. The below diagram illustrates how to patch fixture #1. If all fixtures will be controlled together, skip step 7b.

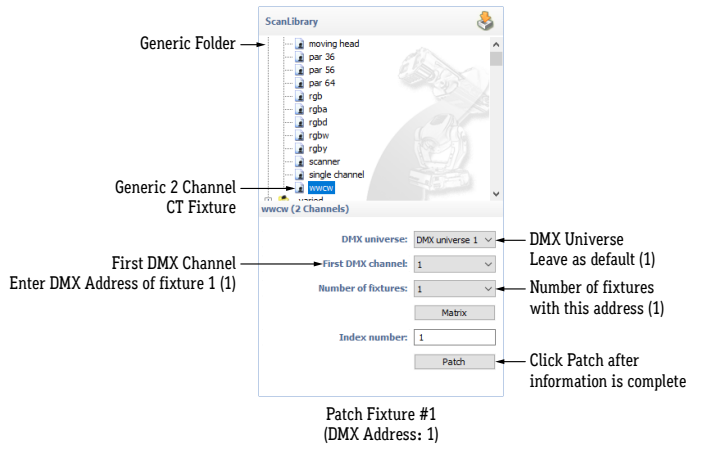



CALIFORNIA
ACCENT
LIGHTING
INC

DMX-CT-128C | INSTALLATION

Operating ESA Software (ALS450T-CT) 2 of 2

7b. Patch fixture #2 and fixture #3.

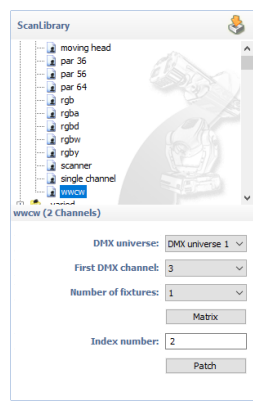

Patch Fixture #2
(DMX Address: 3)

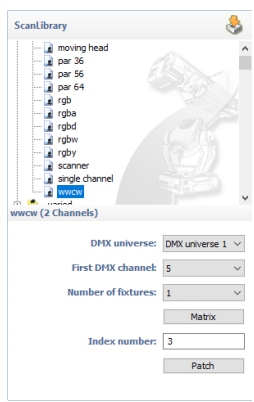

Patch Fixture #3
(DMX Address: 5)

8. To create a custom scene, click on the Editor tab at the top left of the interface. A new, blank scene named New Scene will appear by default.

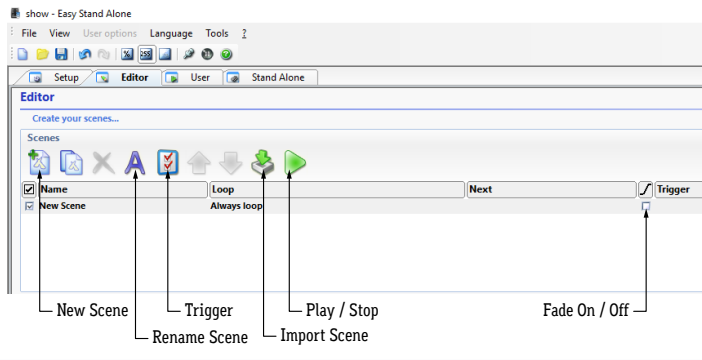

9. Each scene is made up of a series of steps. Create steps using the Steps menu on the upper right of the interface.

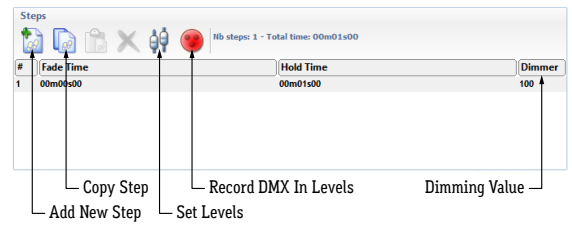

10. Set the color value of each channel for each step. Under the DMX Universe 1 tab, channel 1 - 2 controls the CT value of fixture #1. Channel 3 - 4 controls the CT value of fixture #2. Channel 5 - 6 controls the CT value of fixture #3. Use the slider to set each light level or enter light level in the light level display. Use the arrows at the top and bottom of slider track to fine tune the value.

Example: Channel 1 controls fixture #1 Warm White value (65). Channel 6 controls fixture #2 Cool White value (65). Channel 11 controls fixture #3 Warm White value (65).

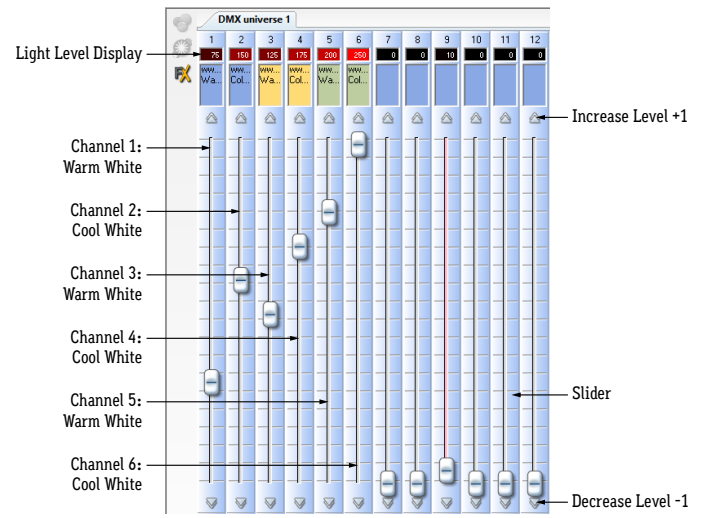

11. After setting CT values, set fade time and hold time in the Steps menu in the upper right of the interface. Double click 00m00s00 under Fade Time, then use the arrow keys to set desired time in minutes and seconds. Double click 00m00s00 under Hold Time, then use the arrow keys to set desired time. Double click Dimmer to set brightness value.

Example: Fade Time: 00m02s00 (2 seconds). Hold Time: 00m04s00 (4 seconds). Dimmer: 100 (100% brightness).

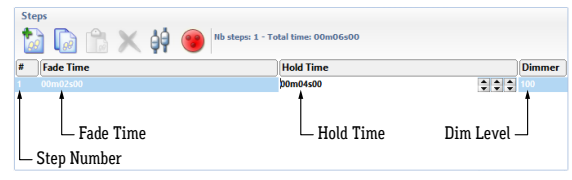

12. Create additional steps as needed by repeating steps 9 - 11. Play your scene and make adjustments to the parameters as desired. When a scene is complete, save as a Show File (.dlm) as a backup on your computer. Create up to 24 scenes using the Editor tab.

13. Save scenes to the DMX Controller by using the Stand Alone tab in the upper left of the interface. Click the write memory button, then click OK. The program will write the scenes into the controller to be used independently from the computer.

Note: Writing the memory will erase all factory-programmed scenes from the controller.

