

SPECIFICATIONS

Table with 2 columns: Specification Name and Value. Rows include Programmability (PC, Mac, Tablet or Smartphone), Software (Easy Stand Alone, ESA2 (PC & Mac)), Output Protocol (DMX-512 (x2)), Channels (1024), Appearance (Black Glass), Connections (Mini USB, Ethernet, RS232, Clock), Input Power (6-7V DC 0.6A), Battery (LIR2032), Memory (microSD (32GB max, 128MB included)), Certifications (EC, EMC, ROHS, ETL, UL), Case Dimensions (5.74" x 4.17" x 0.43"), Weight (0.47 lbs (217g)), and Temperature Rating (-10°C - 45°C).

PRODUCT INFORMATION

- DMX controller with glass face (1024 channels)
9 touch sensitive controls
Package includes controller, USB cable, 128MB microSD with adapter, and power connector
Multi-zone microSD memory
Multi-room control with up to 500 scenes and 10 zones
Live intensity and color settings
Programmable through USB cable and control software
RS232 dry contact port and infrared input port
Clock and calendar with sunrise/sunset triggering
Remote control via network communication
OEM customization of the color palette and logo

INSTALLATION RECOMMENDATIONS

- DMX-CT-1024C can be mounted on a single or double gang wall socket



CALIFORNIA ACCENT LIGHTING INC

DMX-CT-1024C | WALL CONTROLLER

Setup of Controller: Plug-in Connection (LLED8300 & LLED8350)

1. Unbox DMX controller components. You will need the DMX controller, power connector, USB cable, and RJ45 ethernet cable.

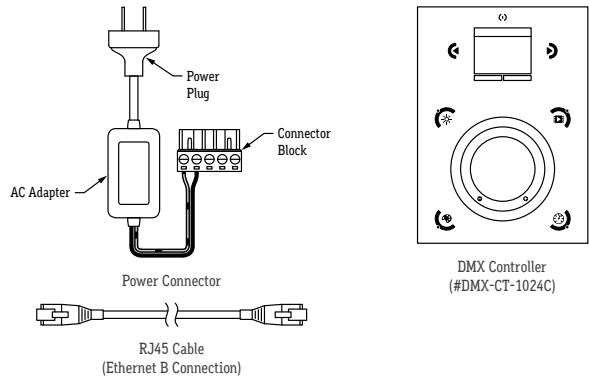

2. Connect one end of RJ45 cable to the DMX input port on DMX-CT-5A. Connect the other end to the DMX output port on the controller (top port). Refer to wiring diagram on page 3 for additional details.
3. Connect power plug to standard 120V outlet.
4. Install Nicolaudie Easy Stand Alone software on your computer. Use software disc or go to <https://www.nicolaudie.com/en/esa.htm> to download software and software manual.
5. Connect controller via USB cable to a computer with Nicolaudie software installed, then program scenes into controller as desired. Remove USB cable after programming is complete. **Note:** See page 10 - 11 for a guide on creating and saving customized scenes.
6. Mount an electrical box (not included) into the wall where controller will be mounted.
7. Insert assembled connector block into the receiving port on the back of controller.

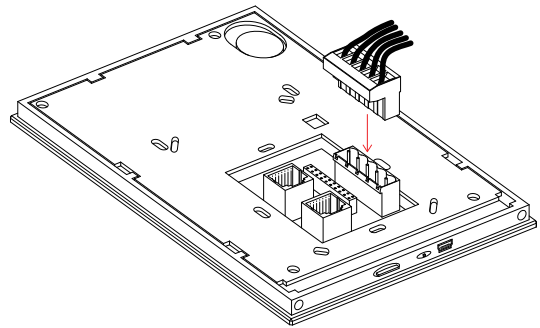

8. To connect controller to a network, connect one end of an RJ45 Ethernet cable to the Ethernet port on the controller (bottom port). Connect the other end of the cable to a router or switch. The controller should connect to the network automatically.
9. Confirm the controller is connected to the network by holding the standby button for 3 seconds until menu appears on screen. Use the arrow buttons to toggle through the menu to Ethernet section. Press the middle "stick" button on the controller to select choice. Toggle through the menu until either DHCP Success or DHCP Fail appears. If DHCP Fail appears, the controller is likely being blocked by a firewall.
10. Download DMX Lightpad 3 or Easy Remote to a mobile device and connect the device to the same network. The app will automatically detect the controller.

11. Remove back plate from front panel. Slide back plate towards the bottom of the controller to disengage the slide lock, then gently remove back plate from front panel. Route wiring from electrical box through the large hole in the back plate of controller.

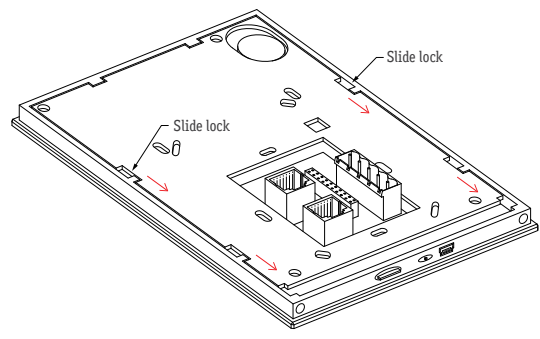

12. Mount controller interface onto the electrical box. Secure with at least two screws, then attach the front panel onto the back plate. Wait at least 30 seconds for the touch sensitivity to adjust.

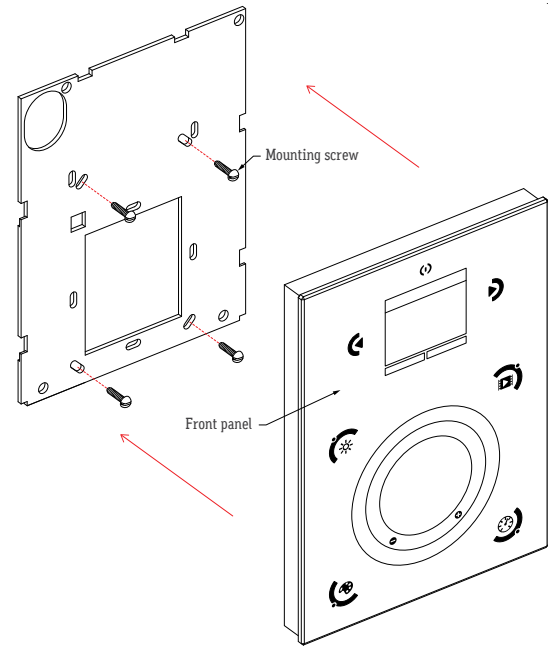



CALIFORNIA
ACCENT
LIGHTING
INC

DMX-CT-1024C | WALL CONTROLLER

Wiring Diagram: Plug-in Connection (LLED8300)

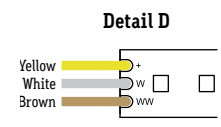
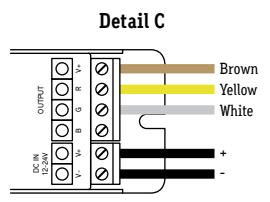
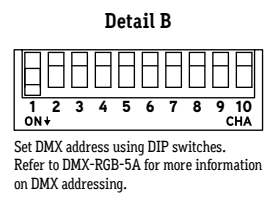
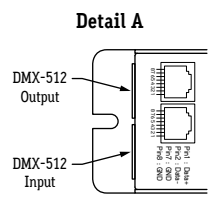
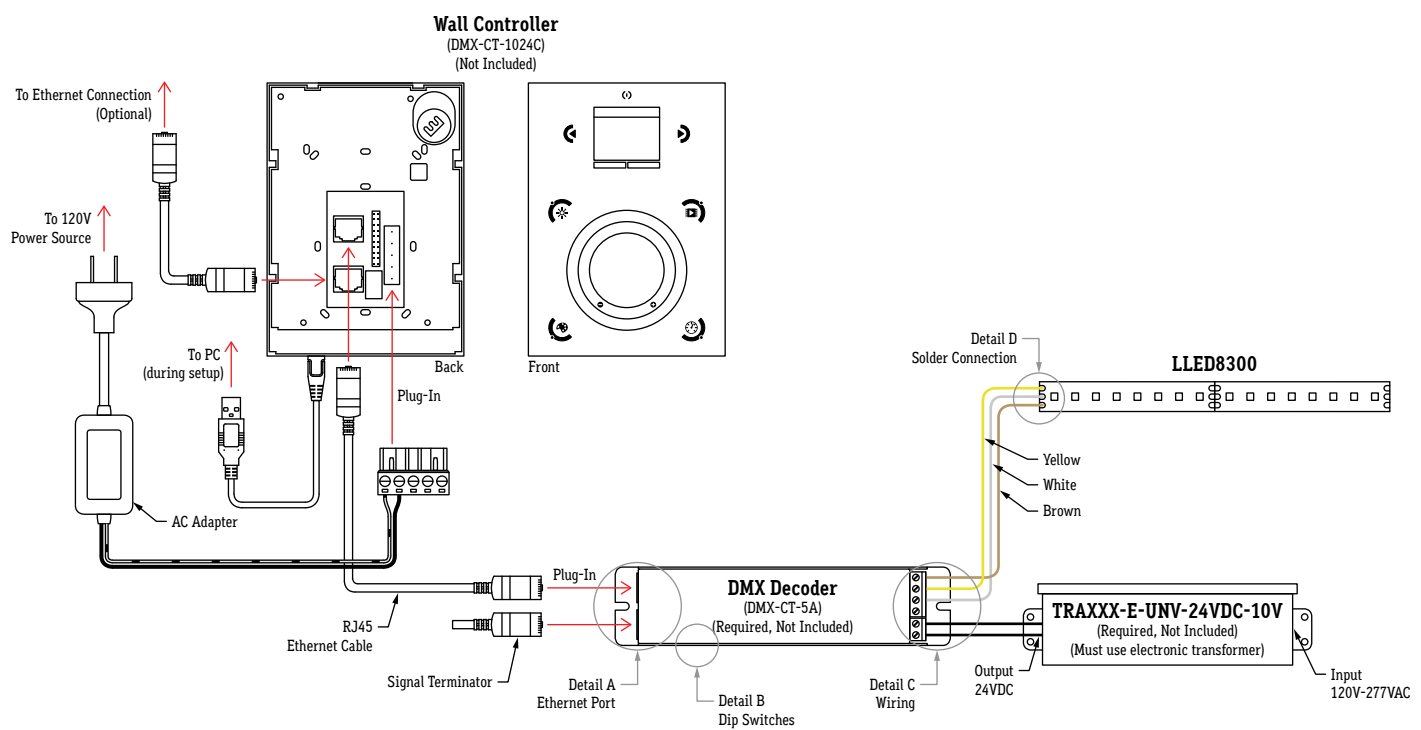



CALIFORNIA
ACCENT
LIGHTING
INC

DMX-CT-1024C | WALL CONTROLLER

Wiring Diagram: Plug-in Connection (LLED8350)

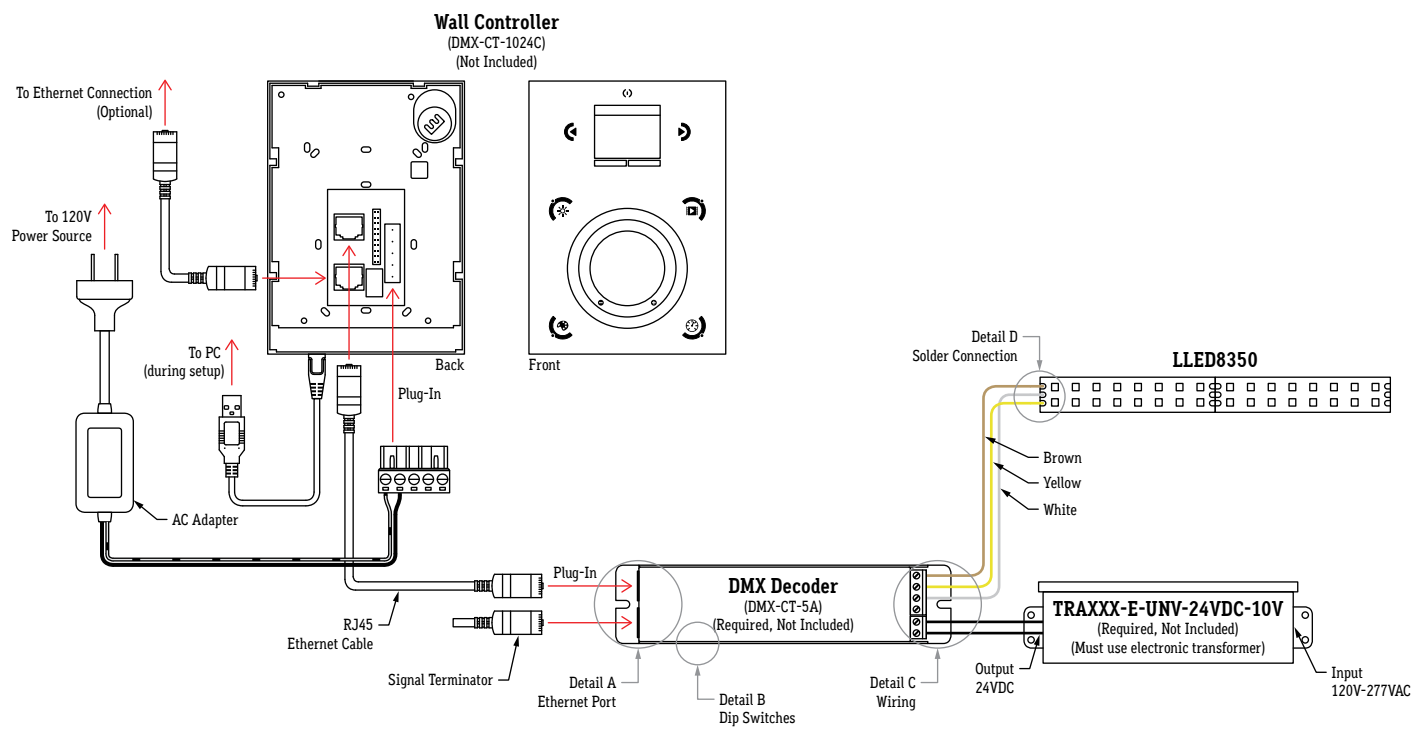

Detail A

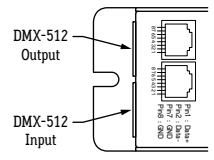

Detail B

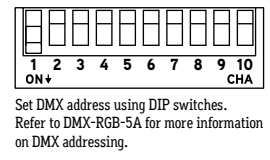

Detail C

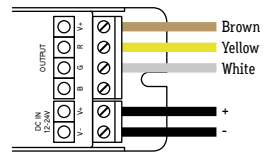

Detail D

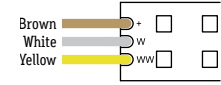



CALIFORNIA ACCENT LIGHTING INC

DMX-CT-1024C | WALL CONTROLLER

Setup of Controller: Hardwire Connection (LLED8300 & LLED8350)

1. Unbox DMX controller components. You will need the DMX controller, power connector, USB cable, and RJ45 ethernet cable.

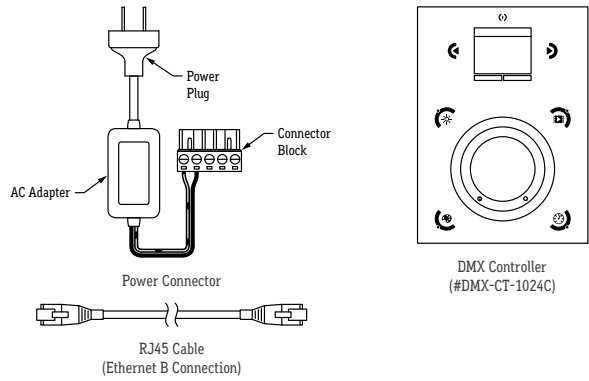

2. Cut one end of RJ45 cable near the connector and strip blue jacket, exposing about 1" of internal wiring. Connect the other end of RJ45 cable to the DMX input port on DMX-CT-5A. Refer to wiring diagram on page 6 for additional details.

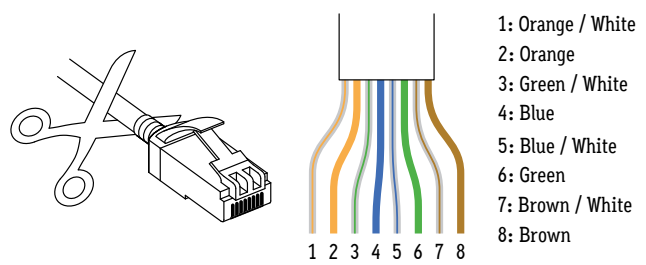

3. Connect 12VDC output wires from AC adapter to connector block. Connect the black / white wire to Power DC+ and the black wire to PowerGround. Connect the brown / white wire to DMX Ground, the orange wire to DMX-, and the orange / white wire to DMX+ in the connector block. Cap off the five remaining wires.

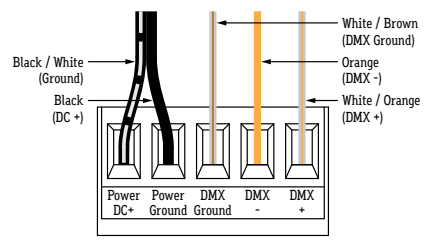

4. Connect power plug to standard 120V outlet.
5. Install Nicolaudie Easy Stand Alone software. Use provided software disc or go to <https://www.nicolaudie.com/en/esa.htm> to download software and software manual.
6. Connect controller via USB cable to a computer with Nicolaudie software installed, then program scenes into controller as desired. Remove USB cable after programming is complete. **Note:** See page 10 - 11 for a guide on creating and saving customized scenes.
7. Mount an electrical box (not included, by others) into the wall where controller will be mounted.

8. Insert assembled connector block into the receiving port on the back of controller.

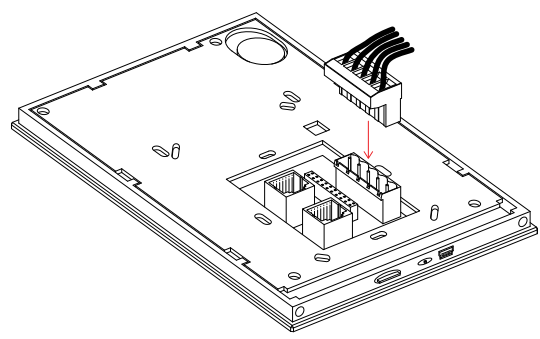

9. To connect controller to a network, connect one end of an RJ45 Ethernet cable to the Ethernet port on the controller (bottom port). Connect the other end of the cable to a router or switch. The controller should connect to the network automatically.
10. Confirm the controller is connected to the network by holding the standby button for 3 seconds until menu appears on screen. Use the arrow buttons to toggle through the menu to Ethernet section. Press the middle "stick" button on the controller to select choice. Toggle through the menu until either DHCP Success or DHCP Fail appears. If DHCP Fail appears, the controller is likely being blocked by a firewall.
11. Download DMX Lightpad 3 or Easy Remote to a mobile device and connect the device to the same network. The app will automatically detect the controller.
12. Remove back plate from front panel. Slide back plate towards the bottom of the controller to disengage the slide lock, then gently remove back plate from front panel. Route wiring from electrical box through the large hole in the back plate of controller.

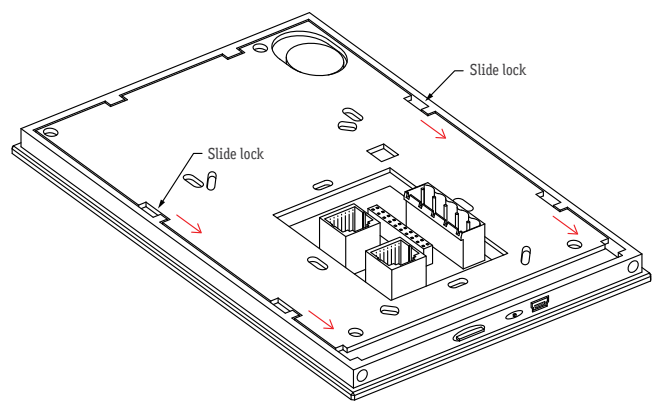

13. Mount controller interface onto the electrical box. Secure with at least two screws, then attach the front panel onto the back plate. Wait at least 30 seconds for the touch sensitivity to adjust.



CALIFORNIA
ACCENT
LIGHTING
INC

DMX-CT-1024C

WALL
CONTROLLER

Wiring Diagram: Hardwire Connection (LLED8300)

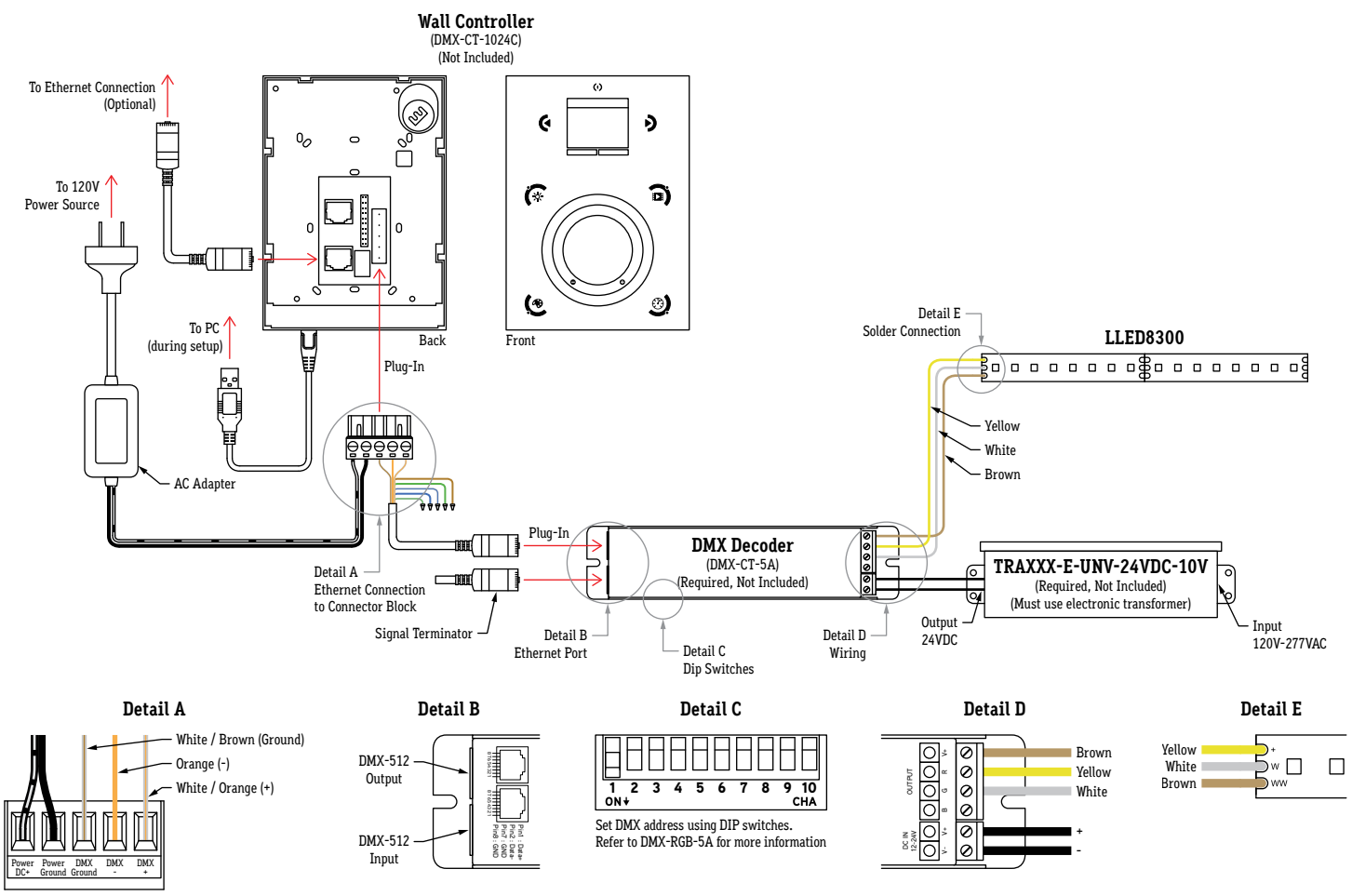



CALIFORNIA
ACCENT
LIGHTING
INC

DMX-CT-1024C | WALL CONTROLLER

Wiring Diagram: Hardwire Connection (LLED8350)

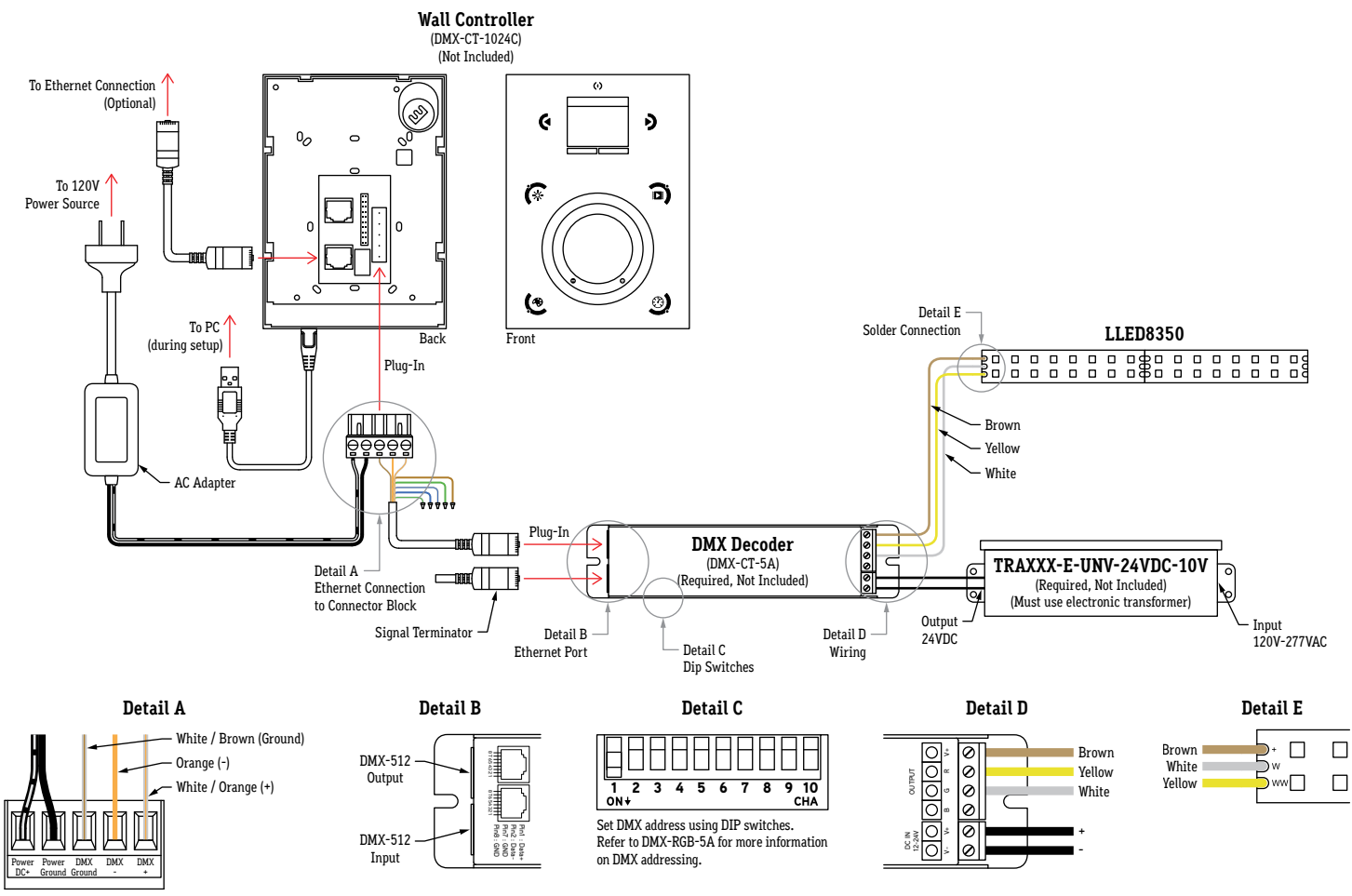



CALIFORNIA ACCENT LIGHTING INC

DMX-CT-1024C | WALL CONTROLLER

Setup of Controller (ALS450T-CT)

1. Unbox DMX controller components. You will need the DMX controller, power connector, software CD-ROM, and USB cable.

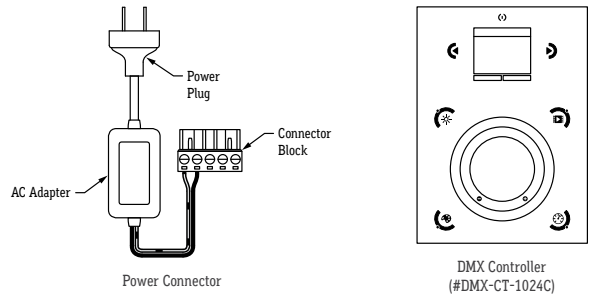

2. Cut the first female data cable near the connector and strip black jacket, exposing about 1" of internal wiring. The first data cable is located underneath the end of fixture with a digital interface on the end cap.

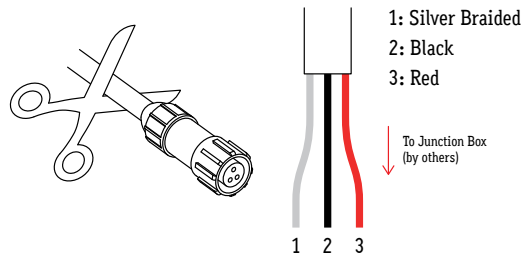

3. Connect 12VDC output wires from AC adapter to connector block. Connect the silver braided wire to DMX Ground, the black wire to DMX-, and the red wire to DMX+ in the connector block.

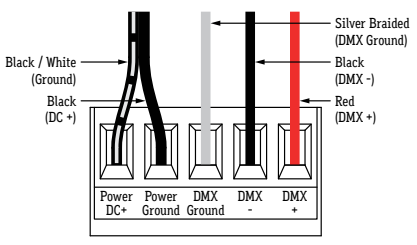

4. Connect power plug to standard 120V outlet.
5. Install Nicolaudie Easy Stand Alone software on your computer. Use software disc or go to <https://www.nicolaudie.com/en/esa.htm> to download software and software manual.
6. Connect controller via USB cable to a computer with Nicolaudie software installed, then program scenes into controller as desired. Remove USB cable after programming is complete. **Note:** See page 12 - 13 for a guide on creating and saving customized scenes.
7. Mount an electrical box (not included) into the wall where controller will be mounted. The controller will fit on a standard 60mm electrical box.

8. Insert assembled connector block into the receiving port on the back of controller.

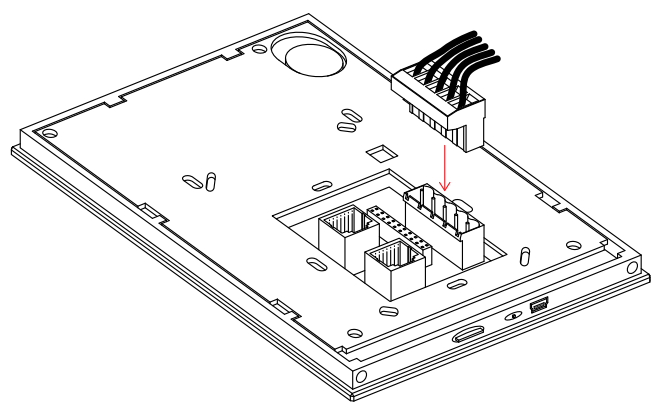

9. To connect controller to a network, connect one end of an RJ45 Ethernet cable to the Ethernet port on the controller (bottom port). Connect the other end of the cable to a router or switch. The controller should connect to the network automatically.
10. Confirm the controller is connected to the network by holding the standby button for 3 seconds until menu appears on screen. Use the arrow buttons to toggle through the menu to Ethernet section. Press the middle "stick" button on the controller to select choice. Toggle through the menu until either DHCP Success or DHCP Fail appears. If DHCP Fail appears, the controller is likely being blocked by a firewall.
11. Download DMX Lightpad 3 or Easy Remote to a mobile device and connect the device to the same network. The app will automatically detect the controller.
12. Remove back plate from front panel. Slide back plate towards the bottom of the controller to disengage the slide lock, then gently remove back plate from front panel. Route wiring from electrical box through the large hole in the back plate of controller.

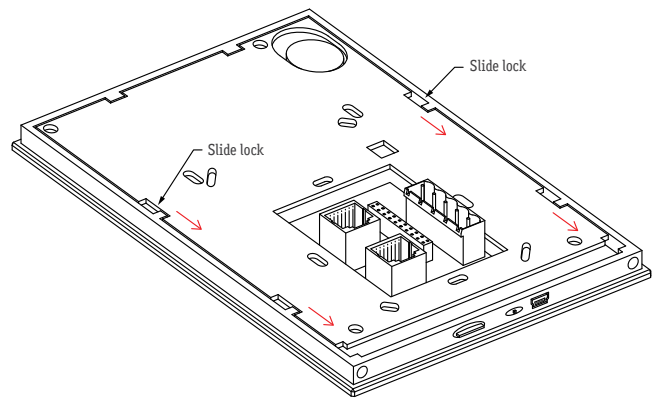

13. Mount controller interface onto the electrical box. Secure with at least two screws, then attach the front panel onto the back plate. Wait at least 30 seconds for the touch sensitivity to adjust.



CALIFORNIA
ACCENT
LIGHTING
INC

DMX-CT-1024C | WALL CONTROLLER

Wiring Diagram (ALS450T-CT)

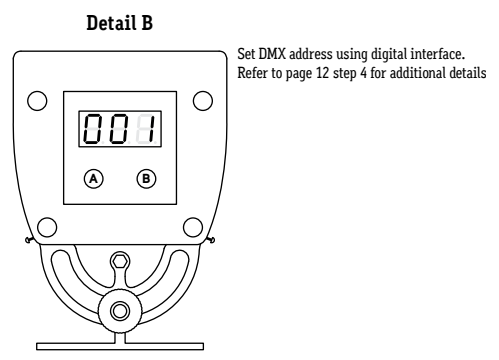
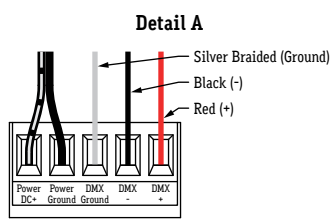
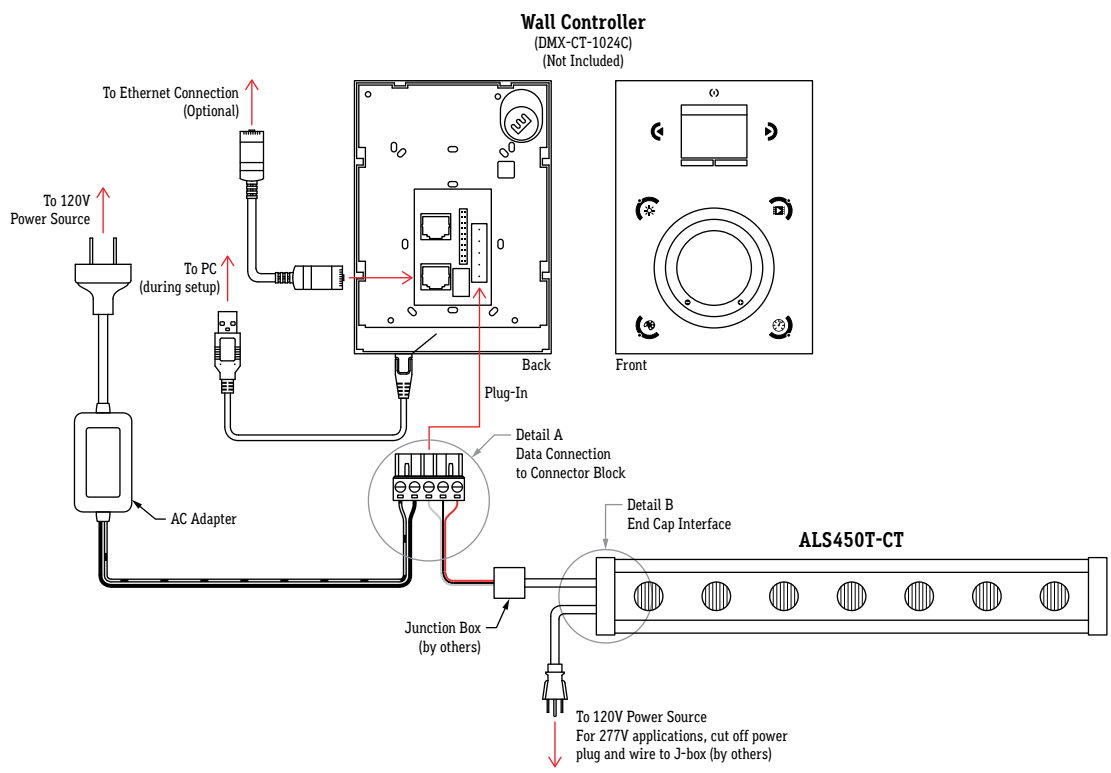

1. Install Nicolaudie Easy Stand Alone software. Use provided software disc or go to <https://www.nicolaudie.com/en/esa.htm> to download software and software manual.
2. Connect controller via USB cable to a computer with Nicolaudie software installed, then open software. The controller does not need to be powered to be programmed; however it is recommended to create scenes while controller and lighting are connected to a computer. This provides instantaneous feedback while creating scenes.
3. The program will display a prompt to select your favorite operating mode. Select the STICK2 option and click OK.

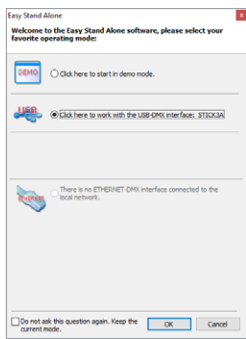

4. Set DMX address for each fixture connected to the controller. Set DMX address using DIP switches on the side of decoder. The sum of the value of each engaged DIP switch creates the DMX address.

Example: 1 + 4 + 32 = 37. DMX start address for this decoder is 37.

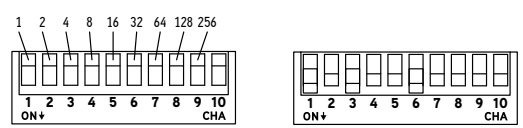

DIP switch value for each switch. Switch 10 has no value (0).

Example: DMX address set to 37. DIP switches 1, 3, and 6 are engaged (on).

5. If all fixtures will be controlled together, continue to step 6a. If each fixture will be controlled independently, continue to step 6b.

- 6a. If all fixtures will be controlled together, set the DMX start address of each fixture to 1.

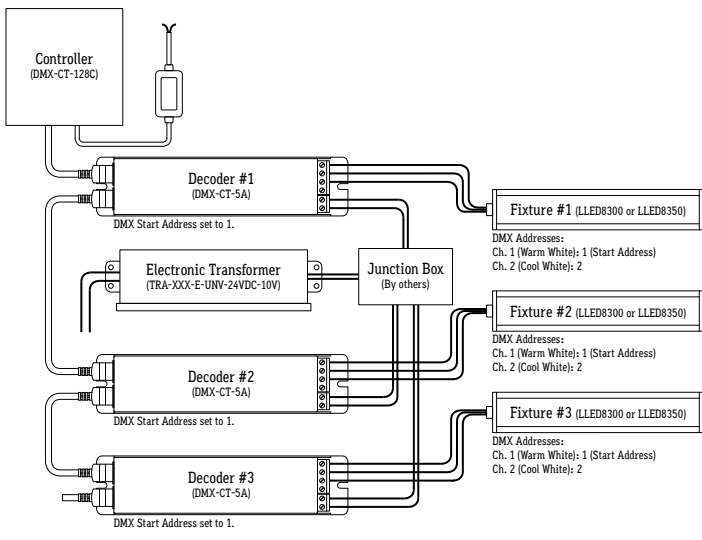

- 6b. If each fixture will be controlled independently, set the DMX start addresses in sequence. The start address controls the first channel (red) of the CT fixture. The second and third channels (green, blue) will automatically be detected by the software and assigned DMX addresses within the DMX universe, which will be detailed later.

Example: 3 fixtures with 1 decoder each. Set the DMX start address of the first fixture to 1. Set the DMX start address of the second fixture to 4. Set the DMX start address of the third fixture to 7, and so on. Refer to the below diagram.

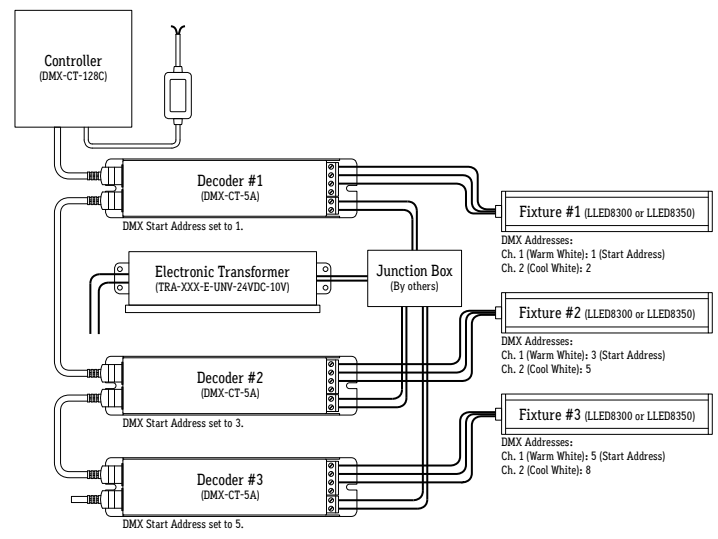

- 7a. The program will open to a blank show file by default. Patch each fixture to the DMX universe using the previously set DMX addresses. Under the Scan Library menu, in the generic folder, select "wvcw". This tells the software that a 2 channel CT fixture is connected to the controller. The below diagram illustrates how to patch fixture #1. If all fixtures will be controlled together, skip step 7b.

Generic Folder
 First DMX Channel
 Enter DMX address of fixture 1 (1)
 Patch fixture #1 (DMX address 1)



CALIFORNIA ACCENT LIGHTING INC

DMX-CT-1024C | WALL CONTROLLER

Operating ESA Software (LLED8300 & LLED8350) cont.

7b. Patch fixture #2 and fixture #3.

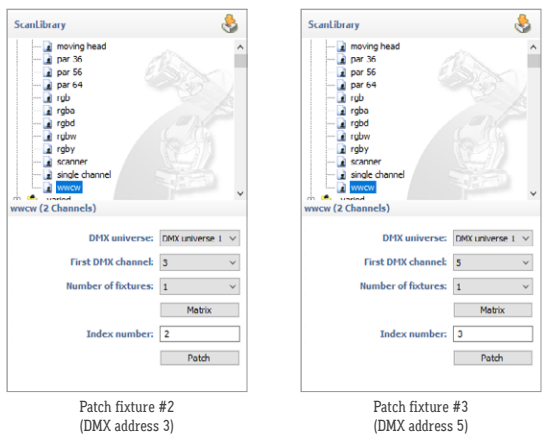

8. To create a custom scene, click on the Editor tab at the top left of the interface. A new, blank scene named New Scene will appear by default.

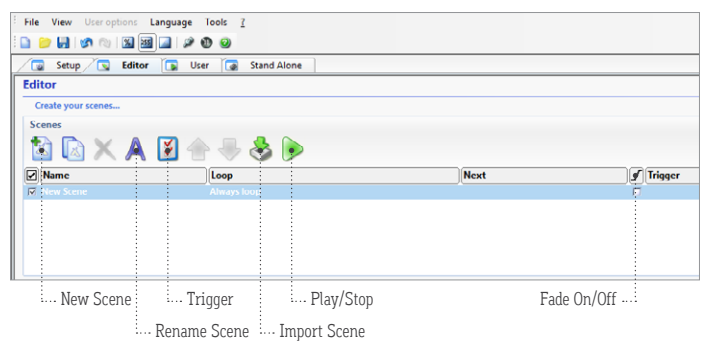

9. Each scene is made up of a series of steps. Create steps using the Steps menu on the upper right of the interface.

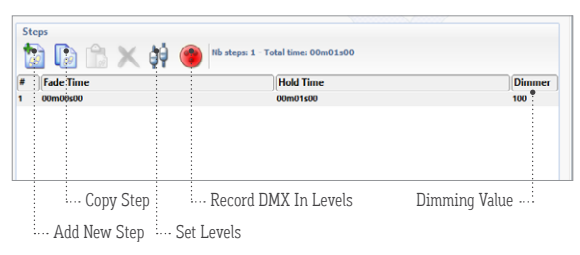

10. Set the color value of each channel for each step. Under the DMX universe 1 tab, channel 1-2 controls the CT value of fixture #1. Channel 3-4 controls the CT value of fixture #2. Channel 5-6 controls the CT value of fixture #3. Use the slider to set each light level or enter light level in the light level display. Use the arrows at the top and bottom of slider track to fine tune the value.

Example: Channel 1 controls fixture #1 warm white value (75). Channel 4 controls fixture #2 cool white value (175). Channel 5 controls fixture #3 warm white value (200).

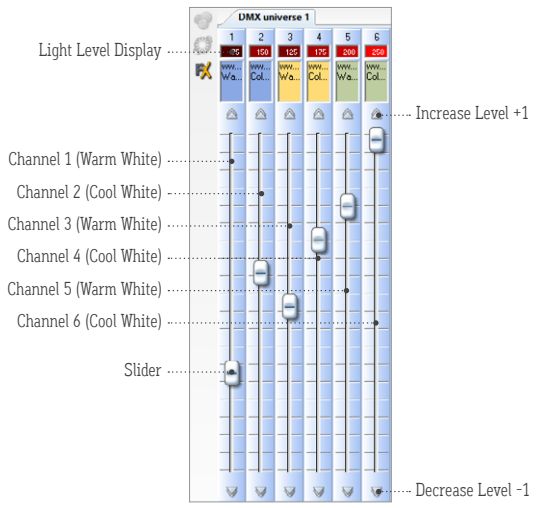

11. After setting CT values, set fade time and hold time in the Steps menu in the upper right of the interface. Double click 00m00s00 under Fade Time, then use the arrow keys to set desired time in minutes and seconds. Double click 00m00s00 under Hold Time, then use the arrow keys to set desired time. Double click Dimmer to set brightness value.

Example: Fade Time - 00m02s00 (2 seconds). Hold Time - 00m04s00 (4 seconds). Dimmer - 100 (100% brightness).

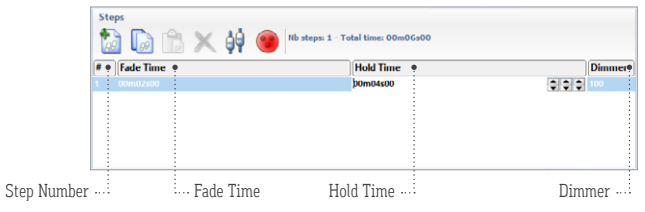

12. Create additional steps as desired by repeating steps 9 - 11. Play your scene and make adjustments to the parameters as desired. When a scene is complete, save as a Show File (.dlm) as a backup on your computer. Create up to 24 scenes using the Editor tab.

13. Save scenes to the DMX-CT-128C controller by using the Stand Alone tab in the upper left of the interface. Click the write memory button, then click OK. The program will write the scenes into the controller to be used independently from the computer.

Note: Writing the memory will erase all 8 factory-programmed scenes from the controller.

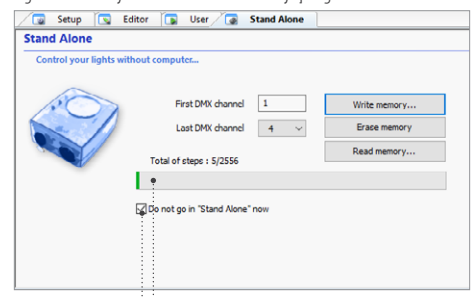

Uncheck if controller will be used exclusively while connected to PC. Total memory usage. Create up to 2556 steps across 24 scenes.

1. Install Nicolaudie Easy Stand Alone software. Use provided software disc or go to <https://www.nicolaudie.com/en/esa.htm> to download software and software manual.
2. Connect controller via USB cable to a computer with Nicolaudie software installed, then open software. The controller does not need to be powered to be programmed; however it is recommended to create scenes while controller and lighting are connected to a computer. This provides instantaneous feedback while creating scenes.
3. The program will display a prompt to select your favorite operating mode. Select the STICK2 option and click OK.
4. Set DMX address for each fixture connected to the controller. Set DMX address using digital interface on end cap of fixture.

Example: PXY value is 001. DMX address is 1.

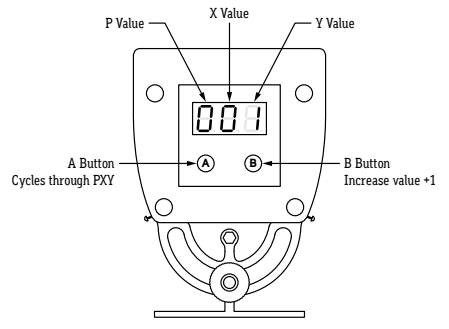

5. If all fixtures will be controlled together, continue to step 6a. If each fixture will be controlled independently, continue to step 6b.

6a. If all fixtures will be controlled together, set the DMX start address of each fixture to 1.

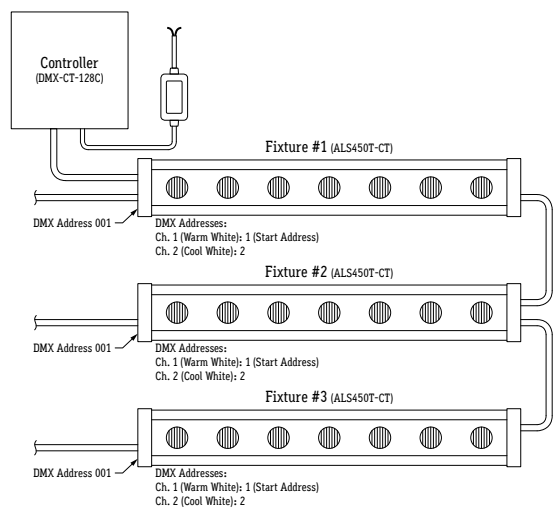

- 6b. If each fixture will be controlled independently, set the DMX start addresses in sequence. The start address controls the first channel (red) of the CT fixture. The second and third channels (green, blue) will automatically be detected by the software and assigned DMX addresses within the DMX universe, which will be detailed later.

Example: 3 ALS450T-CT fixtures. Set the DMX start address of the first fixture to 1. Set the DMX start address of the second fixture to 4. Set the DMX start address of the third fixture to 7, and so on. Refer to the below diagram.

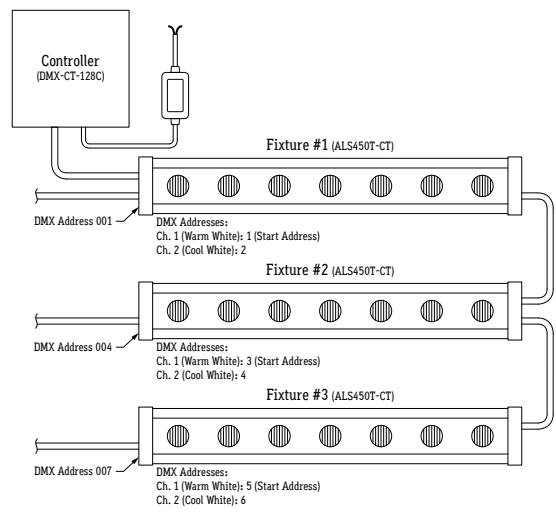

- 7a. The program will open to a blank show file by default. Patch each fixture to the DMX universe using the previously set DMX addresses. Under the Scan Library menu, in the generic folder, select "wvcw". This tells the software that a 2 channel CT fixture is connected to the controller. The below diagram illustrates how to patch fixture #1. If all fixtures will be controlled together, skip step 7b.

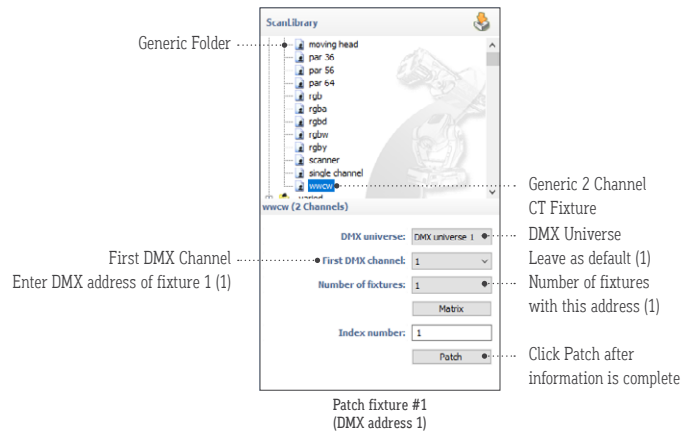



CALIFORNIA ACCENT LIGHTING INC

DMX-CT-1024C | WALL CONTROLLER

Operating ESA Software (ALS450T-CT) cont.

7b. Patch fixture #2 and fixture #3.

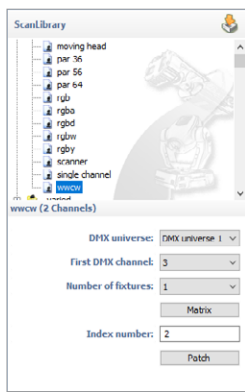

Patch fixture #2 (DMX address 3)

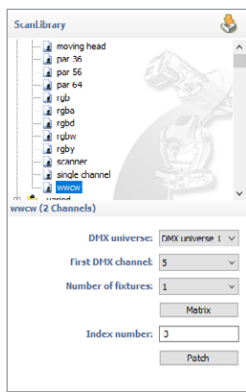

Patch fixture #3 (DMX address 5)

8. To create a custom scene, click on the Editor tab at the top left of the interface. A new, blank scene named New Scene will appear by default.

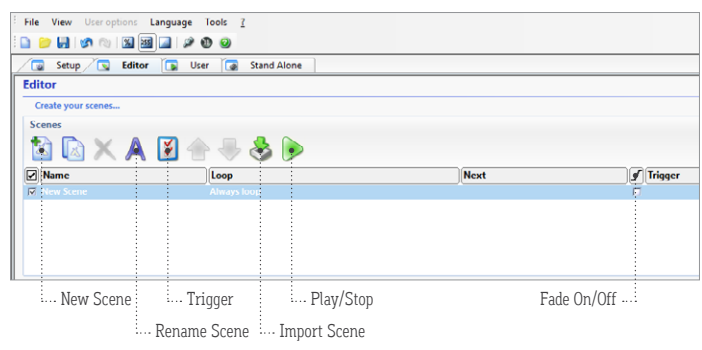

9. Each scene is made up of a series of steps. Create steps using the Steps menu on the upper right of the interface.

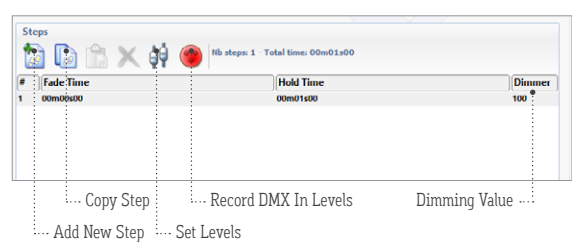

10. Set the color value of each channel for each step. Under the DMX universe 1 tab, channel 1-2 controls the CT value of fixture #1. Channel 3-4 controls the CT value of fixture #2. Channel 5-6 controls the CT value of fixture #3. Use the slider to set each light level or enter light level in the light level display. Use the arrows at the top and bottom of slider track to fine tune the value.

Example: Channel 1 controls fixture #1 warm white value (75). Channel 4 controls fixture #2 cool white value (175). Channel 5 controls fixture #3 warm white value (200).

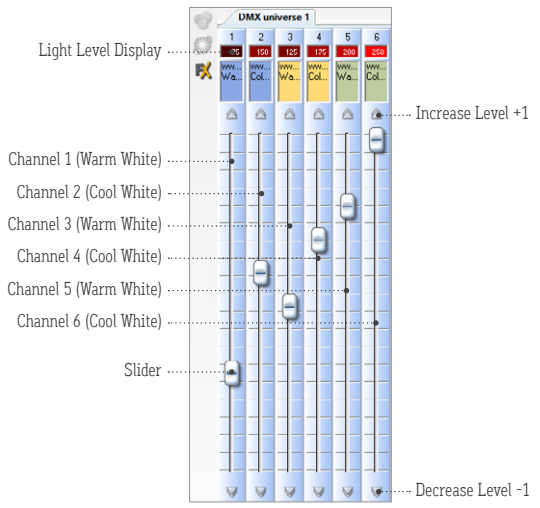

11. After setting CT values, set fade time and hold time in the Steps menu in the upper right of the interface. Double click 00m00s00 under Fade Time, then use the arrow keys to set desired time in minutes and seconds. Double click 00m00s00 under Hold Time, then use the arrow keys to set desired time. Double click Dimmer to set brightness value.

Example: Fade Time - 00m02s00 (2 seconds). Hold Time - 00m04s00 (4 seconds). Dimmer - 100 (100% brightness).

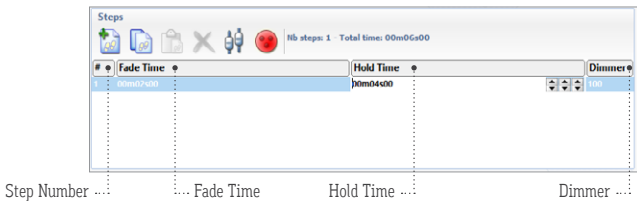

12. Create additional steps as desired by repeating steps 9 - 11. Play your scene and make adjustments to the parameters as desired. When a scene is complete, save as a Show File (.dm) as a backup on your computer. Create up to 24 scenes using the Editor tab.

13. Save scenes to the DMX-CT-128C controller by using the Stand Alone tab in the upper left of the interface. Click the write memory button, then click OK. The program will write the scenes into the controller to be used independently from the computer.

Note: Writing the memory will erase all 8 factory-programmed scenes from the controller.

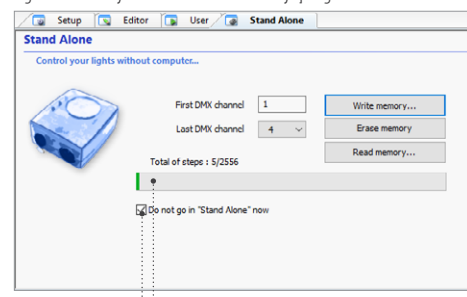

Uncheck if controller will be used exclusively while connected to PC. Total memory usage. Create up to 2556 steps across 24 scenes.